



MODEL 4050B-EB SERIES

All electric wipe-on print-apply labeling system

The **Weber Model 4050B-EB** wipe-on, is a high-speed, modular, all electric print-apply system featuring high-resolution printing and easy in-field repairs. Available in left or right-hand configurations, its electric-driven belt eliminates the need for air, providing accurate and efficient product labeling on your production line.

STANDARD FEATURES

- + Electric belt wipe-on for higher speeds and accuracy
- + Motorized label unwinder for reduced wear on print engine and smooth feeding of the supply roll
- + Zebra and Sato print engine compatible; 203, 300 and 600 dpi available
- + Available with RFID capability
- + Label on-belt detection
- + Heavy-duty 24/7 usage

7" TOUCH DISPLAY INTERFACE

- + Made of rugged aluminum construction, with single-key calibration, and easy access to various settings and alerts

VERSATILE LABELING

- + The 4050B-EB can be oriented to apply labels to the top, bottom or sides of packages
- + The stepper driven belt can be adjusted for different product labeling needs
- + Numerous I/O's to allow interfacing with many types of external devices



Scan here for more info

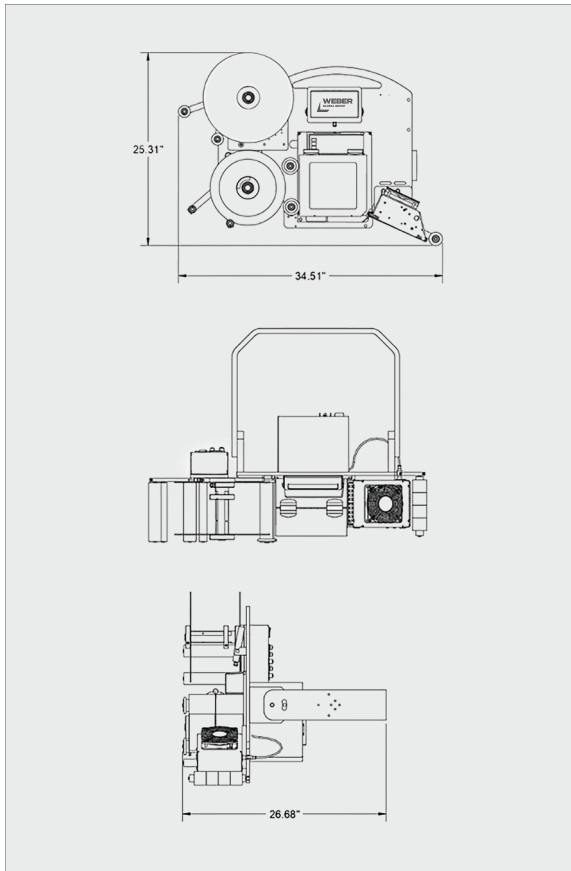

TECHNICAL DATA

- + **Dimensions (EB Model)**
- 34.5" x 25.3" x 26.7"

- + **Weight (EB Model)**
- Starting at 113 lbs (51kg), version dependent (without labels)

- + **Electrical**
- 90/263 VAC/50-60Hz (1PH), 580W

- + **Product Sensing**
- Photoelectric

- + **Label Roll Size**
- Up to 12" O.D. (300mm) 3" (76mm) core (outside wound)

- + **Label Size Range**
- Min width: 2.0" Max width: 6.0"
- Min length: 2.0" Max length: 8.0"

- + **Label Styling**
- Die-cut, waste-removed with a minimum of 0.125" (3mm) separation between labels in running direction

- + **Label Placement**
- Accurate to ± 0.04 " (1.0mm) when labels are produced to specifications and product handling is controlled

- + **Labeling Speed**
- Up to 240 labels per min (label size & stroke length dependent)

- + **Labeling Software Required**
- Print information needs to be sent to the print engine before label can be dispensed and applied

- + **Options**
- Adjustable stand
- Three-color stack light
- Sato & Zebra print engines (203, 300 & 600dpi)
- RFID print engine upgrade
- I/O easy wiring terminal connection box

WEBER Packaging Solutions, Inc.

711 West Algonquin Road
Arlington Heights / IL / 60005
1.800.843.4242 / info@weberpackaging.com



WEBER Marking Systems Canada

6180 Danville Road
Mississauga / ON / L5T 2H7
1.800.265.9974 / info@webermarking.ca

